

# Sure-Flex Plus® Coupling Flange Types J, S, SC, B, C

Installation Instructions

P-7888-TBW



 **TB Wood's®**  
*Altra Industrial Motion*

**TEKMATIC**

Distribuidor exclusivo para la República Argentina  
T. 011 4222 5040 - F. 011 4201 2478  
www.tekmatic.com.ar - info@tekmatic.com.ar

**▲ WARNING** Lock out / tag out the power source before proceeding to avoid unexpected starts. Failure to observe these precautions could result in bodily injury.

**▲ WARNING** Coupling sleeves may be thrown from the assembly with substantial force if subjected to a severe shock load.

**▲ CAUTION** Check operating speed against maximum RPM value in Table 1.

**▲ CAUTION** Rubber (EPDM / Neoprene) and Hytrel sleeves have different ratings. Do not use rubber and Hytrel sleeves interchangeably or the sleeve will fail prematurely.

For a basic installation overview, scan the QR code below:



Scan to Watch  
Installation Video  
or visit:  
[www.TBWoods.com/SureFlexPlus](http://www.TBWoods.com/SureFlexPlus)

Further component information available:

Specification sheets, 3D models  
[ecatalog.TBWoods.com](http://ecatalog.TBWoods.com)

Coupling Selection Program  
[www.TBWoods.com/Select](http://www.TBWoods.com/Select)

## Installation / Alignment

### Installation / Alignment Tools

- Hex key set
  - [SC Spacer coupling: Socket set]
  - Torque wrench
  - Straight-edge
  - Caliper
  - Feeler gauge set
1. Inspect all coupling components and remove any protective coatings or lubricants from bores, mating surfaces and fasteners. Remove any existing burrs, etc. from the shafts. (If using a two-piece E or N sleeve, do not install the wire ring at this time.)
  2. SC Spacer couplings: using a torque wrench, bolt hubs to flanges to values in Table 2. This flange/hub combination will be referred to as “flange” in these instructions.

3. Slide one flange onto each shaft using keys where required. (When using Type B flanges, follow the instructions furnished with the Sure Grip bushings.)

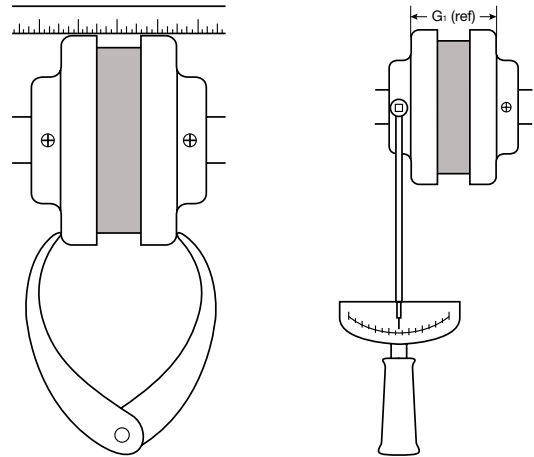

4. Position the flanges on the shafts to approximately achieve the  $G_1$  dimension shown in Table 1, with an equal length of shaft extending into each flange. Note: minimum shaft engagement is  $0.85 \times$  shaft diameter. Tighten set screw(s) of one flange to values in Table 2 using a torque wrench.
5. Slide back the unfastened flange and install the sleeve. The sleeve should be seated against both flanges but not compressed. When using a two-piece sleeve, do not install the wire ring yet but let it hang loosely in the groove adjacent to the teeth. Tighten set screw(s) of the second flange to values in Table 2 using a torque wrench.
6. Parallel Alignment: Without rotating the coupling, run a straight-edge around the outside of the coupling flanges – see Figure 1. Find the maximum offset with feeler gauges; this measurement must not exceed the figure shown under “Parallel” in Table 1. If necessary, realign the shafts.
7. Angular Alignment: Without rotating the coupling, run a caliper around the outside of the flange faces just inboard of the OD – see Figure 1. Set the caliper to the widest point. Find the narrowest point with the caliper and feeler gauges; this measurement must not exceed the figure given under “Angular” in Table 1. If a correction is necessary, recheck parallel alignment.

8. Tighten motor and driven equipment fasteners to manufacturer specifications; recheck parallel and angular alignment.
9. When parallel and angular alignment values are within service ratings, verify that all set screws and other fasteners are tightened to values in Table 2. Recheck parallel and angular alignment after tightening.
10. If the coupling uses a two-piece sleeve with the wire ring, move the ring into its groove in the center of the sleeve. If necessary, use soapy water and lever the ring with a wrench or blunt screwdriver.
11. Install coupling guard per applicable safety regulations.
12. Periodically check alignment, as settling can change equipment position.

**Table 1 - Maximum RPM and Allowable Misalignment**

Sleeve Size	Max RPM	G <sub>1</sub> (ref)		Type JE, JN, JES, JNS, E, N				Type H, HS*			
				Parallel		Angular		Parallel		Angular	
		in	mm	in	mm	in	mm	in	mm	in	mm
3	9200	1.2	30	0.010	0.25	0.035	0.89	-	-	-	-
4	7600	1.5	38	0.010	0.25	0.043	1.09	-	-	-	-
5	7600	1.9	49	0.015	0.38	0.056	1.42	-	-	-	-
6	6000	2.4	60	0.015	0.38	0.070	1.78	0.010	0.25	0.016	0.41
7	5250	2.6	65	0.020	0.51	0.081	2.06	0.012	0.31	0.020	0.51
8	4500	2.9	75	0.020	0.51	0.094	2.39	0.015	0.38	0.025	0.64
9	3750	3.5	89	0.025	0.64	0.109	2.80	0.017	0.43	0.028	0.71
10	3600	4.1	103	0.025	0.64	0.128	3.21	0.020	0.51	0.032	0.81
11	3600	4.9	124	0.032	0.81	0.151	3.89	0.022	0.56	0.037	0.94
12	2800	5.7	145	0.032	0.81	0.175	4.44	0.025	0.64	0.042	1.07
13	2400	6.6	170	0.040	1.02	0.195	4.95	0.030	0.76	0.050	1.27
14	2200	7.8	200	0.045	1.14	0.242	6.15	0.035	0.89	0.060	1.52
16	1500	10.2	260	0.062	1.58	0.330	7.38	-	-	-	-

\*H and HS sleeves should not be used as replacements for EPDM or Neoprene Sleeves

Note: When using a VFD with a centrifugal pump or fan, reduce allowable parallel and angular alignment values by half

**Table 2 - Fastener Torque Values**

Size	Type J		Type S		Type SC*				Type B		Type C			
	Set Screws		Set Screws		Cap Screws Flange to Hub		Set Screws		Cap Screws		Clamping Screws		Set Screws	
	ft-lbs	Nm	ft-lbs	Nm	ft-lbs	Nm	ft-lbs	Nm	ft-lbs	Nm	ft-lbs	Nm	ft-lbs	Nm
3	3	4	-	-	-	-	-	-	-	-	-	-	-	-
4	3	4	-	-	5.5**	8**	7	10	-	-	-	-	-	-
5	7	10	7	10	4	6	13	18	-	-	-	-	-	-
6	13	18	13	18	9	12	13	18	5	7	15	21	13	18
7	-	-	13	18	9	12	13	18	5	7	30	41	13	18
8	-	-	23	31	18	24	23	31	9	12	55	75	13	18
9	-	-	23	31	31	42	23	31	9	12	55	75	13	18
10	-	-	23	31	50	68	50	68	15	20	100	136	13	18
11	-	-	23	31	75	102	50	68	30	41	100	136	13	18
12	-	-	50	68	150	203	100	136	60	81	200	271	13	18
13	-	-	100	136	150	203	165	226	75	102	-	-	-	-
14	-	-	100	136	150	203	165	226	75	102	-	-	-	-
16	-	-	100	136	-	-	-	-	135	183	-	-	-	-

\* Torque values apply to hub size when different than flange size

\*\* Values for socket head clamping screw

## TB Wood's Facilities

### North America

#### USA

440 North Fifth Avenue  
Chambersburg, PA 17201 - USA  
888-829-6637 \* 717-264-7161  
*Belted Drives and Elastomeric Couplings*

#### Customer Service

1-888-829-6637 (Press #5)

#### For Application Support

1-888-829-6637 (Press #7)

2000 Clovis Barker Road  
San Marcos, TX 78666 - USA  
1-888-449-9439  
*General Purpose Disc Couplings*

#### Customer Service

1-888-449-9439

4970 Joule St  
Reno, NV 89502 - USA  
775-857-1800

#### Canada

9779 45 Ave NW  
Edmonton, AB T6E 5V8 - Canada  
+1 780-439-7979

6305 Danville Road  
Mississauga, ON L5T 2H7 - Canada  
1-800-829-6631

1073 Rue Bégin  
Saint-Laurent, QC H4R 1V8 - Canada  
+1 514-332-4812

#### Mexico

Comisión Federal de Electricidad 850,  
Industrial San Luis,  
San Luis, S.L.P., 78395 - Mexico  
+52 444 137 1500

### Europe

Merchant Drive, Hertford  
Hertfordshire SG13 7BL - England  
+44(0)1992 501900  
*Elastomeric Couplings*

## The Brands of Altra Industrial Motion

### Couplings

**Ameridrives**  
[www.ameridrives.com](http://www.ameridrives.com)

**Bibby Turboflex**  
[www.bibbyturboflex.com](http://www.bibbyturboflex.com)

**Guardian Couplings**  
[www.guardiancouplings.com](http://www.guardiancouplings.com)

**Huco**  
[www.huco.com](http://www.huco.com)

**Lamiflex Couplings**  
[www.lamiflexcouplings.com](http://www.lamiflexcouplings.com)

**Stromag**  
[www.stromag.com](http://www.stromag.com)

**TB Wood's**  
[www.tbwoods.com](http://www.tbwoods.com)

### Linear Systems

**Thomson**  
[www.thomsonlinear.com](http://www.thomsonlinear.com)

### Geared Cam Limit Switches

**Stromag**  
[www.stromag.com](http://www.stromag.com)

### Engineered Bearing Assemblies

**Kilian**  
[www.kilianbearings.com](http://www.kilianbearings.com)

### Electric Clutches & Brakes

**Matrix**  
[www.matrix-international.com](http://www.matrix-international.com)

**Stromag**  
[www.stromag.com](http://www.stromag.com)

**Warner Electric**  
[www.warnerelectric.com](http://www.warnerelectric.com)

**Deltran**  
[www.thomsonlinear.com](http://www.thomsonlinear.com)

### Belted Drives

**TB Wood's**  
[www.tbwoods.com](http://www.tbwoods.com)

### Heavy Duty Clutches & Brakes

**Twiflex**  
[www.twiflex.com](http://www.twiflex.com)

**Stromag**  
[www.stromag.com](http://www.stromag.com)

**Svendborg Brakes**  
[www.svendborg-brakes.com](http://www.svendborg-brakes.com)

**Wichita Clutch**  
[www.wichitaclutch.com](http://www.wichitaclutch.com)

### Gearing & Specialty Components

**Bauer Gear Motor**  
[www.bauergears.com](http://www.bauergears.com)

**Boston Gear**  
[www.bostongear.com](http://www.bostongear.com)

**Delevan**  
[www.delevan.com](http://www.delevan.com)

**Delroyd Worm Gear**  
[www.delroyd.com](http://www.delroyd.com)

**Nuttall Gear**  
[www.nuttallgear.com](http://www.nuttallgear.com)

### Engine Braking Systems

**Jacobs Vehicle Systems**  
[www.jacobsvehiclesystems.com](http://www.jacobsvehiclesystems.com)

### Precision Motors & Automatic

**Kollmorgen**  
[www.kollmorgen.com](http://www.kollmorgen.com)

### Miniature Motors

**Portescap**  
[www.portescap.com](http://www.portescap.com)

### Overrunning Clutches

**Formsprag Clutch**  
[www.formsprag.com](http://www.formsprag.com)

**Marland Clutch**  
[www.marland.com](http://www.marland.com)

**Stieber**  
[www.stieberclutch.com](http://www.stieberclutch.com)

Neither the accuracy nor completeness of the information contained in this publication is guaranteed by the company and may be subject to change in its sole discretion. The operating and performance characteristics of these products may vary depending on the application, installation, operating conditions and environmental factors. The company's terms and conditions of sale can be viewed at <http://www.altramotion.com/terms-and-conditions/sales-terms-and-conditions>. These terms and conditions apply to any person who may buy, acquire or use a product referred to herein, including any person who buys from a licensed distributor of these branded products.

©2019 by TB Wood's LLC. All rights reserved. All trademarks in this publication are the sole and exclusive property of TB Wood's LLC or one of its affiliated companies.



[www.tbwoods.com](http://www.tbwoods.com)

2000 Clovis Barker Road  
San Marcos, TX 78666  
512-353-4000

P-7888-TBW 12/19



Distribuidor exclusivo para la República Argentina  
T. 011 4222 5040 - F. 011 4201 2478  
[www.tekmatic.com.ar](http://www.tekmatic.com.ar) - [info@tekmatic.com.ar](mailto:info@tekmatic.com.ar)